

Industrial Clutch Products

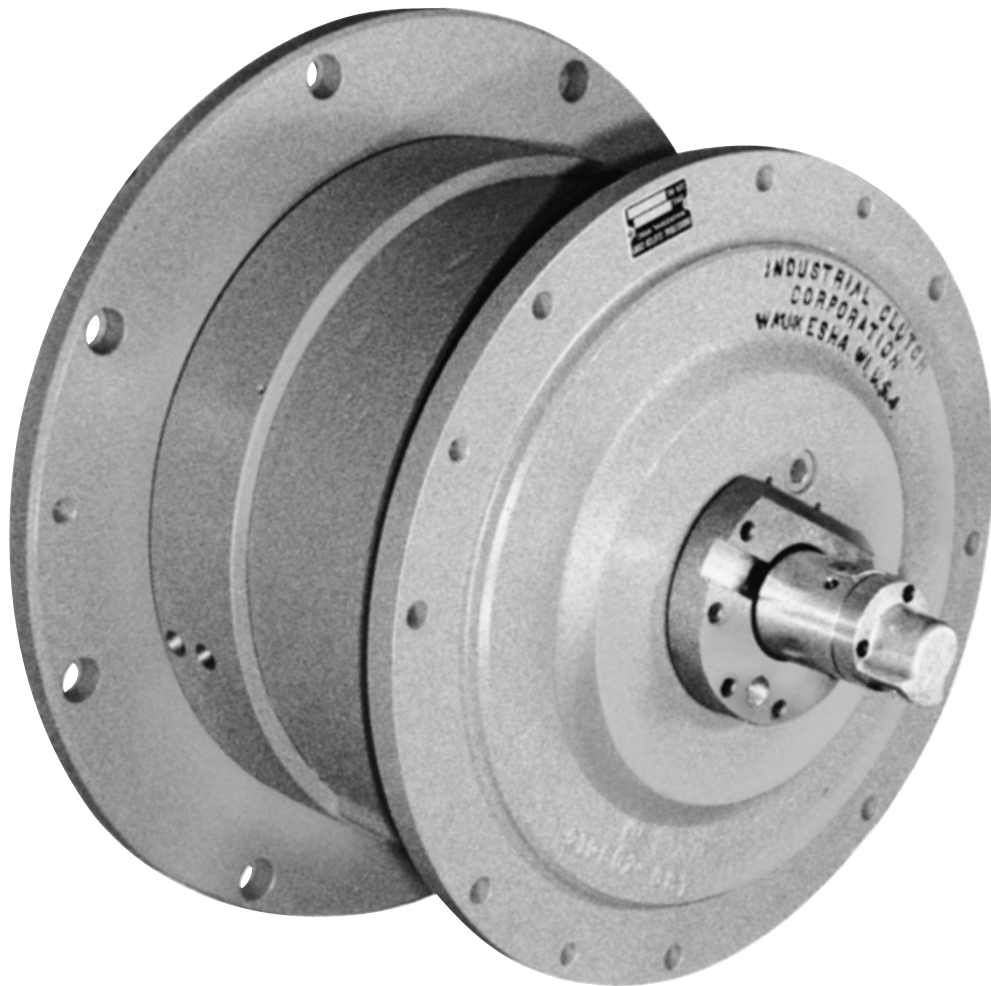

MODEL CBH

Hydraulically Actuated Combination Clutch-Brakes

Model CBH

Hydraulically Actuated Combination Clutch Brakes

PERFORMANCE CHARACTERISTICS

The Model CBH combination clutch-brakes are oil immersed units with a spring-set brake and hydraulically-set clutch. They are designed for extremely high cyclic rates and for those applications that require a high degree of stopping accuracy.

Hydraulic actuation and precise control of piston stroke contributes to an extremely fast response time. Actuation volumes are very small and the fluid's virtually incompressible characteristics means that piston motion times can be as low as 5-10 milliseconds. This, in turn, allows for more shaft motion time since the unit's hydraulic response time is so short. Cyclic rates in excess of 300 cpm are not uncommon in some applications.

Such high cyclic rates induce a large amount of shock into the mechanical components of the unit and all members are designed to withstand these loads. Oil films help dampen these shock loads and the units run extremely quiet. Noise reductions of 25-30 dBA are common when compared to dry units running at the same speeds and loads.

Wear characteristics of the Model CBH units are excellent. As an example, a Model CBH unit was endurance tested for 120 million cycles with no appreciable lining or mechanical wear. A dry unit was tested at the same load level and found to require re-line every 10 million cycles and complete unit replacement every 30 million cycles. There are many industrial applications which require longevities of this magnitude and the Model CBH has exhibited outstanding performance in these instances.

ADVANTAGES

- Combination clutch-brake eliminates the possibility of clutch-brake fight
- Hydraulic actuation for fastest possible response time
- Impervious to adverse operating environments
- Wear virtually non-existent
- Capable of high cyclic rates
- Extreme stopping accuracy
- Quiet operation

USAGES

ORIGINAL EQUIPMENT

Machinery which cycle frequently and requires the ultimate performance with respect to life, reliability, and accuracy.

CONVERSIONS

Machinery which is being upgraded to increase production or reliability.



*Strippit® Model 1250M
 30 metric ton turret punch press uses
 a Model CBH-4010 clutch-brake*

Photo courtesy of Strippit, Inc., a unit of IDEX Corp.

MODEL CBH COMBINATION CLUTCH-BRAKE DESCRIPTION

The Model CBH combination clutch-brake is arranged so it may be mounted in an end of shaft configuration. The unit is a self-contained, oil cooled, hydraulically actuated combination clutch-brake designed for maximum capacity in a minimum space envelope.

The unit contains a spring-set, hydraulically released brake while the clutch is hydraulically-set and spring released. The clutch-brake action is effected using a shuttling piston actuator which moves axially to engage either the clutch or brake. With this arrangement, it is not possible to engage the clutch and brake simultaneously so the possibility of clutch or brake overlap does not exist.

The Model CBH unit uses only the best quality, time proven materials within its construction and has been designed to withstand the rigors of high cyclic applications with precision machined clearances to provide the fastest possible response.

The input flywheel, gear, or sheave is bolted to the clutch driving member. The clutch-brake's inner or driven members can be keyed or splined to the machine's output shaft for maximum driving torque capacity and ease of assembly.

The stationary brake member is affixed to the machine frame through the use of a brake mounting plate provided by others.

The stationary housing provides a sealed cavity for the oil that cools the clutch-brake disc packs. If external cooling is required, this housing provides a means of oil entry and exit.

The cylinder/piston actuating mechanism has been integrated within the brake hub thereby eliminating the need for cross-drilling actuation oil entry holes in the user's shaft and the possibility of leakage at the hub/shaft interface.

The Model CBH combination clutch-brake is available with high-cyclic rate actuation valve assemblies as well as combination cooling/actuation hydraulic power units.

HYDRAULICALLY ACTUATED COMBINATION CLUTCH/BRAKE

**Model
 CBH**

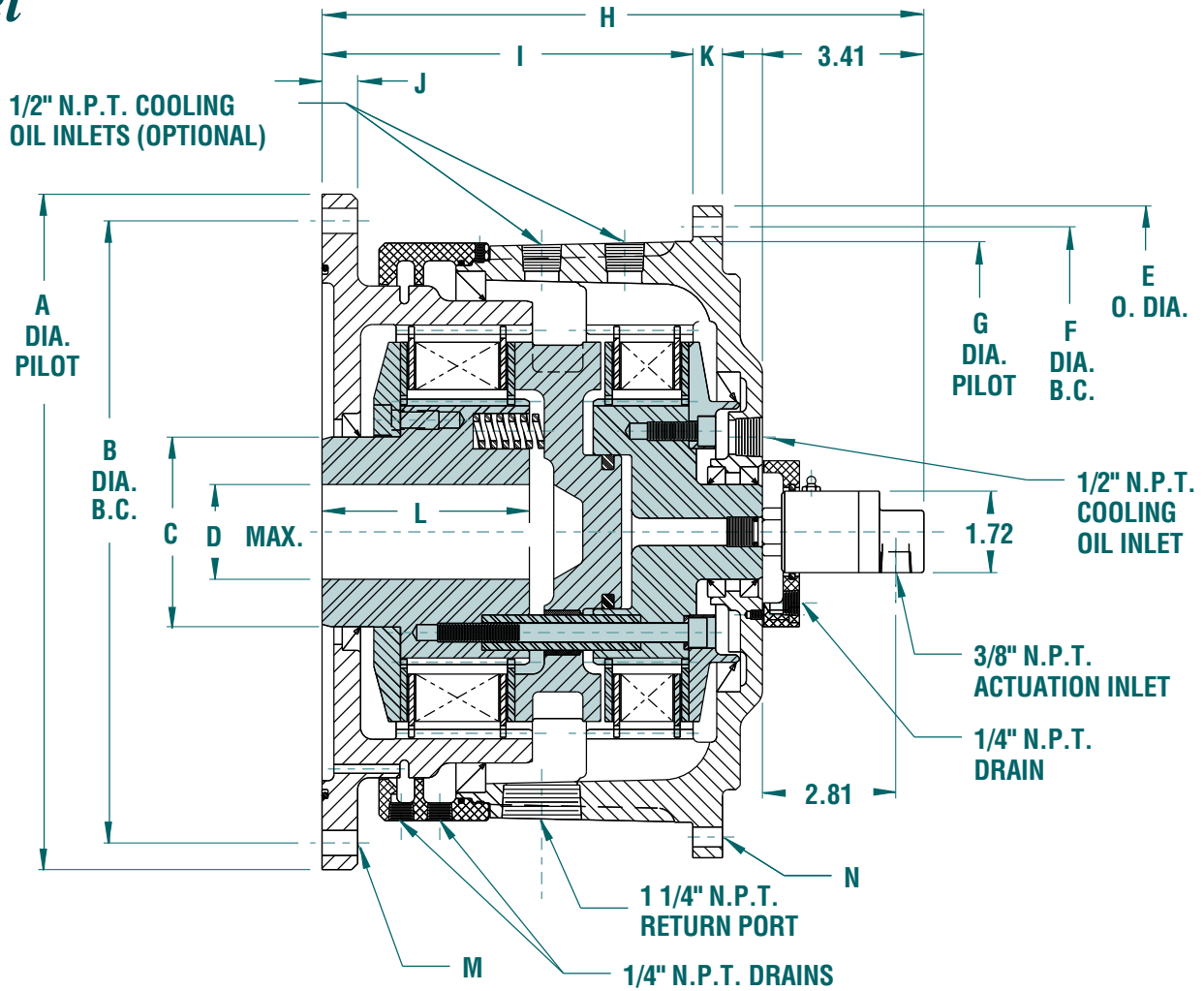

DIMENSIONAL DATA

All dimensions in inches

CBH Model	A	B	C	D	E	F	G	H	I	J	K	L	M	N
3010	16.498	15.25	4.00	2.938	13.75	12.88	12.249	12.71	7.79	0.75	0.63	4.38	(8).53	(8).42
4010	16.498	15.25	4.00	2.938	13.75	12.88	12.249	12.71	7.79	0.75	0.63	4.38	(8).53	(8).42
5010	16.498	15.25	4.00	2.938	13.75	12.88	12.249	13.00	8.08	0.75	0.63	4.67	(8).53	(8).42
5012	16.498	15.25	4.00	2.938	13.75	12.88	12.249	13.32	8.40	0.75	0.63	4.67	(8).53	(8).42
6012	16.498	15.25	4.50	3.500	15.88	15.00	14.374	12.56	7.52	0.75	0.63	4.11	(8).53	(8).42
7015	16.498	15.25	4.50	3.500	15.88	15.00	14.374	13.20	8.16	0.75	0.63	4.11	(8).53	(8).42
8015	16.498	15.25	4.50	3.500	15.88	15.00	14.374	13.52	8.48	0.75	0.63	4.43	(8).53	(8).42
9020	16.498	15.25	4.50	3.500	15.88	15.00	14.374	14.16	9.12	0.75	0.63	4.75	(8).53	(8).42

NOTES: 1.) Use certified drawing dimensions only for final layouts.
 2.) DXF and IGES files available upon request.

3.) Dimensions subject to change without notice.
 4.) All threaded fasteners are metric

OPERATIONAL DATA

CBH Model	Clutch Torque (lb.-in.)	Brake Torque (lb.-in.)	Actuation Volume (in. ³)	Weight Outer (lbs.)	Weight Inner (lbs.)	Weight Stationary (lbs.)	Weight Total (lbs.)	WR ² - Outer (lb.-ft. ²)	WR ² - Inner (lb.-ft. ²)	Maximum Speed (RPM)
3010	30,000	10,000	0.75	44.0	63.1	74.9	182	7.06	3.35	800
4010	40,000	10,000	0.75	46.0	69.1	74.9	190	7.24	3.64	800
5010	50,000	10,000	0.75	47.0	72.0	74.9	194	7.33	4.03	800
5012	50,000	12,000	0.75	47.0	75.1	75.9	198	7.33	4.17	800
6012	60,000	12,000	1.13	69.0	87.0	106.8	263	15.52	5.85	675
7015	70,000	15,000	1.13	70.3	95.4	106.8	273	15.80	6.40	675
8015	80,000	15,000	1.13	71.6	99.6	106.8	278	16.10	6.70	675
9020	90,000	20,000	1.13	72.9	108.3	108.1	289	16.30	7.30	675

NOTES: 1.) Operating pressure: 900 PSIG
 2.) Torque capacities can be modified. Consult engineering.

TURRET PUNCH PRESS APPLICATION

Turret punch presses are one example of where the Model CBH combination clutch-brakes have been successfully applied on both original equipment as well as conversion replacements for dry clutch and brakes on existing machines.

Turret punch presses are ideal candidates for the operating features the Model CBH units can offer.

- LONGEVITY
- RELIABILITY
- QUIET OPERATION
- STOPPING ACCURACY
- REPEATABLE OPERATION
- GREATLY REDUCED MAINTENANCE
- INCREASED MACHINE PRODUCTIVITY
- ELIMINATES WEAR PARTICLES
- ELIMINATES AIR LUBRICATOR MIST
- ELIMINATES AIR SUPPLY REQUIREMENTS

Industrial Clutch Products has been building clutches and brakes for turret punch presses for over 30 years and can state without reservation that the Model CBH combination clutch-brake provides the user of this equipment an extremely high degree of reliability and longevity.

CONVERSIONS

The Model CBH is ideally suited for conversion of older turret punch presses to state of the art oil-immersed clutch-brakes.

Virtually all of the turret punch presses in the field today can be converted within a minimal timeframe and budget. Paybacks are rapid and in most older installations the machine productivity can be increased by over 50%.

The process involves obtaining a conversion kit provided by Industrial Clutch Products (see photos). The existing clutch-brake or separate clutch and brake is removed and a mounting bracket is fabricated to attach the Model CBH to the press frame. Crankshaft mounting diameters and flywheel mounting bolt circles are preserved in the majority of cases as the Model CBH can be modified to mount directly to, or through the use of an adapter, directly to these surfaces. All former clutch and brake air equipment is stripped from the press frame as it is no longer required. The valve assembly is mounted and hoses and power are run to the hydraulic power unit. The control is modified to provide a single valve signal for both the clutch and brake function. The unit is then ready for operation. (Refer to schematic-next page.)

Industrial Clutch Products will be pleased to provide conversion assistance to ensure a successful installation.

Conversion Kit

*Model CBH
Clutch-Brake*



*Actuation
Valving*



*Hydraulic
Power Unit*

TYPICAL TURRET PUNCH PRESS INSTALLATION

